

7-D STYLE GUTTER AND ACCESSORIES

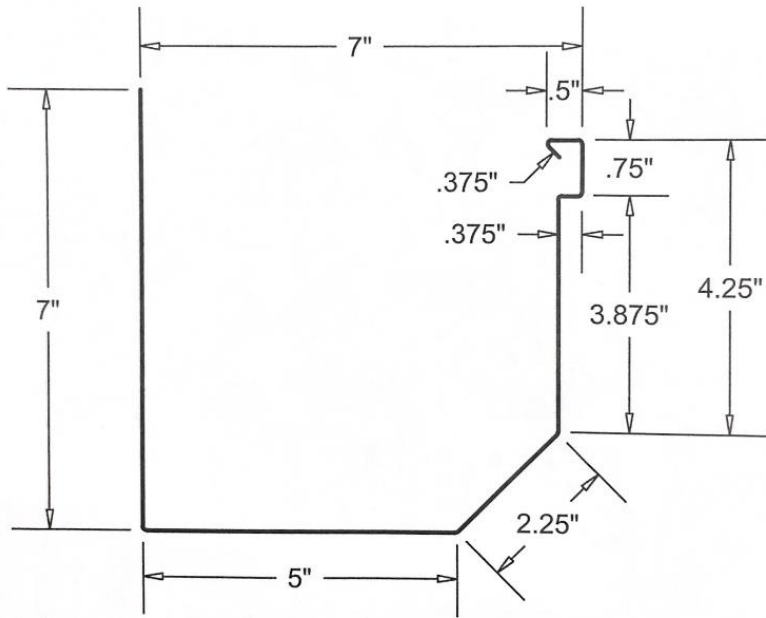

MATERIAL:

- ___ 22GA STEEL
- ___ 24GA STEEL
- ___ 26GA STEEL (LIMITED COLOR AVAILABILITY)

- ___ 24GA STAINLESS STEEL
- ___ 26 GA STAINLESS STEEL

- ___ .032 ALUMINUM
- ___ .040 ALUMINUM
- ___ .050 ALUMINUM

- ___ 16 OZ COPPER
- ___ 20 OZ COPPER

COLOR: _____

GUTTER SUPPORT BRACKETS

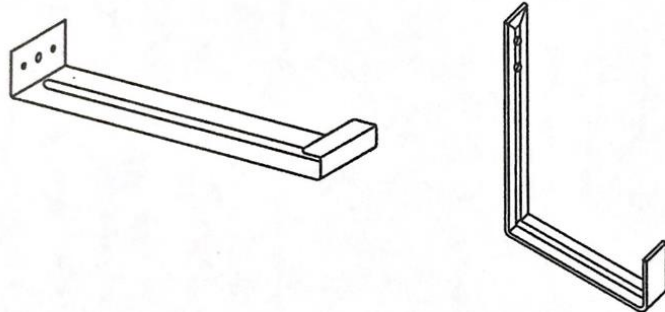

QUANTITIES:

- ___ LINEAL FEET @ 10'-0" LENGTHS (1)
- ___ OUTSIDE MITERS @ 90°
- ___ INSIDE MITERS @ 90°
- ___ ENDCAPS: RIGHT ___ LEFT ___
- ___ EXPANSION JOINTS
- ___ HIDDEN HANGERS
- ___ GUTTER SUPPORT BRACKETS

NOTES:

(1) Subject to minimum requirements

PRINT APPROVED BY:

X

 SIGNATURE DATE

A SIGNED PRINT APPROVAL SIGNIFIES A CUSTOMER HAS VERIFIED ALL DIMENSIONS, SIZES, QUANTITIES, AND MATERIAL TYPES. FABRICATION WILL PROCEED ONLY AFTER RECEIPT OF SIGNED PRINT APPROVAL.

PROJECT INFORMATION

 (PROJECT NAME)

 (ARCHITECT)

 (CUSTOMER)

 (REPRESENTATIVE/DISTRIBUTOR)



Paul Matlock
 (636) 575-3892
 (636) 234-5344
 2290 Country Club Estates Dr.
 Pacific, MO 63069